

ES SERIES - LIGHTWEIGHT



ES1330L/ES1530L ELECTRIC SCISSOR LIFTS - INDOOR AND OUTDOOR RATED *reachingout*®

Performance

Platform Height–Elevated (Indoor/Outdoor)		
ES1330L	13 ft / 13 ft	3.8 m / 3.8 m
ES1530L	15 ft / 10 ft	4.5 m / 3 m
Platform Capacity (Indoor/Outdoor)		
ES1330L	500 lb / 500 lb	227 kg / 227 kg
ES1530L	500 lb / 500 lb	227 kg / 227 kg
Capacity on Platform Extension	250 lb	115 kg
Number of Occupants (Indoor/Outdoor)		
ES1330L	2 / 1	
ES1530L	1 / 1	
Lift/Lower Time	25/15 seconds	
Maximum Drive Height	Fully Elevated	
Weight*		
ES1330L	1,984 lb	900 kg
ES1530L	1,940 lb	880 kg
Ground Bearing Pressure		
ES1330L	119 psi	8.3 kg/cm ²
ES1530L	116 psi	8.1 kg/cm ²
Drive Speed–Elevated	0.5 mph	0.8 km/h
Drive Speed–Lowered	2.4 mph	3.8 km/h
Gradeability	25%	
Tilt Rating		
Fore and Aft	3.0 degrees	
Side to Side		
ES1330L - Indoor/Outdoor	1.75 degrees / 1.5 degrees	
ES1530L - Indoor/Outdoor	2.5 degrees / 1.5 degrees	
Turning Radius (Inside)	Zero	
Turning Radius (Outside)	55 in	1.4 m

* Certain options or country standards will increase weight.

Standard Specifications

Power Source

Batteries	2 x 12V 105 amp-hr
Charger	27 Amp
Drive	24V Electric DC

Hydraulic Reservoir

• Capacity	1.3 gal	5 L
• Pump	Fixed Displacement Gear	

Tires

• Tire Size/Type (Non-Marking)	10 x 3 in	255 x 75 mm
--------------------------------	-----------	-------------

Brakes

- Electric/Friction



**NOW
OUTDOOR
RATED**

Standard Features

- Proportional Controls
- Battery Condition Indicator
- All Motion Alarm
- DeltaQ - 27 amp Multi-Function Universal Charger
- Horn
- Hourmeter
- Tilt Alarm and Light
- AC Receptacle in Platform
- Active Pothole Protection System
- Lifting and Tie Down Points
- Fork Lift Pockets
- Lanyard Attach Points
- Steel Swing-Out Doors
- Visual Variable Tilt Indicator
- Manual Descent Cable
- Diamond Tread Steel Deck
- Greaseless Kingpin Joints
- Analyzer Port for Diagnostics
- Dynamic Braking
- Movable, Removable Platform Control
- Nickel Plated Pins
- Lubrication Free Scissor Arm Bushings
- Scissor Maintenance Prop
- 22 in. (55 cm) Foot-Actuated Deck Extension
- Removable Ladder
- Self Closing Gate
- Load Sensing System

Accessories & Options

- Anti-Vandalism Package
- Coiled Platform Control Box Cable
- Flashing Amber Beacon - LED
- Dual Flashing Amber Beacons - LED
- JLG™ Mobile Control
- MDI (Ground)
- CleanGuard™

020 8351 3434

ES SERIES - LIGHTWEIGHT



ES1330L/ES1530L ELECTRIC SCISSOR LIFTS - INDOOR AND OUTDOOR RATED *reachingout*®

Dimensions

All dimensions are approximate.

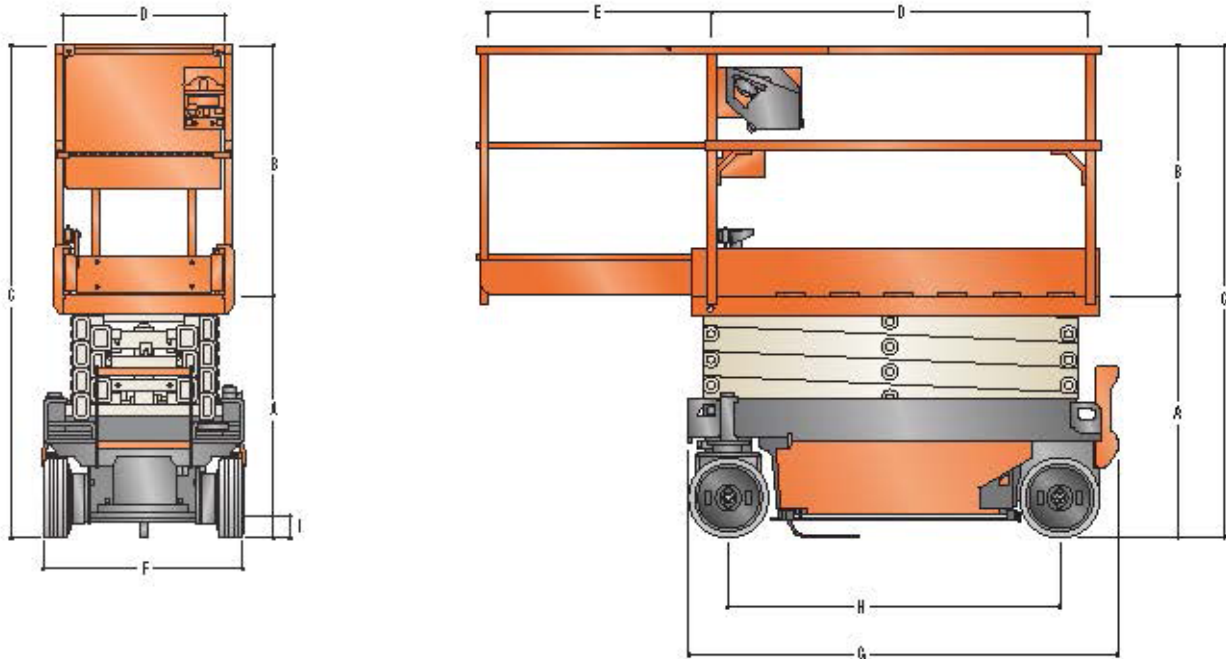

A. Platform Height-Lowered					
ES1330L	28.0 in.	0.7 m	E. Platform Extension	21.6 in.	55 cm
ES1530L	31.1 in.	0.8 m	F. Overall Width	30.0 in.	76 cm
B. Platform Railing Height	43.3 in.	1.1 m	G. Overall Length	56.2 in.	1.4 m
C. Overall Height			H. Wheelbase	42.3 in.	1.1 m
ES1330L	71.7 in.	1.8 m	I. Ground Clearance	2.4 in.	6 cm
ES1530L	74.8 in.	1.9 m			
D. Platform Size	24.4 x 49.2 in.	0.6 x 1.3 m			

@mrplanthireuk mr_plant_hire @mrplanthireuk @mrplanthireuk
Head office: 120 Hertford Road, Enfield EN3 5AX | e: info@mrplanthire.co.uk

020 8351 3434