

020 8351 3434

G.Tripod GSE230C GSE230S



User Instruction Manual

(Original Instructions)

Issue 02

A transportable, temporary anchor device, for use with appropriate and tested fall arrest/retrieval devices.

EN795 Class B, PPE Anchor Device.

EN1496:2017

PD CEN/TS 16415:2013

BS EN ISO 12100:2010

Machinery Directive 2006/42/EC

The Supply Of Machinery (Safety) Regulations 2008 (as amended)

Regulation EU 2016 425

PPE Regulation (EU) 2016/425 as brought into UK Law and amended



@mrplanthireuk mr_plant_hire @mrplanthireuk @mrplanthireuk

Head office: 120 Hertford Road, Enfield EN3 5AX | e: info@mrplanthire.co.uk

Contents

Notified Body/Approved Body Responsible:	3
EU Type Examination Certification	3
UKCA Type Examination Certification	3
Ongoing Conformity (Module D) (CE)	3
Ongoing Conformity (Module D) (UKCA)	3
1. Important Notice	4
2. G.Tripod	5
3. Considerations For Use.	6
4. Inspection Before Use	7
5. Setup For Use	7
a. Attaching To The G.Tripod	7
6. Inspection & Maintenance	9
a. Periodic Examination (This satisfies the requirements of LOLER).	9
b. Service, Test & Re-Certification	9
c. Cleaning, Storage & Transportation	9
7. G.Tripod Specifications	10
8. Examination Record Card	11

Notified Body/Approved Body Responsible:

EU Type Examination Certification

Machinery Directive

SGS Fimko Ltd.

Takomotie 8,00380 Helsinki, Finland

Notified Body Number: 0598.

SATRA Technology Europe Ltd,

Bracetown Business Park,

Clonee,

Co. Meath

D15 YN2P

Ireland.

Notified Body Number 2777

UKCA Type Examination Certification

SATRA Technology Centre,

Wyndham Way,

Telford Way,

Kettering,

Northamptonshire,

NN16 8SD,

United Kingdom

Approved Body Number 0321

Ongoing Conformity (Module D) (CE)

Machinery Directive

SGS Fimko Ltd.

Takomotie 8,00380 Helsinki, Finland

Notified Body Number: 0598.

Ongoing Conformity (Module D) (UKCA)

Personal Protective Equipment

SGS United Kingdom Limited

Rossmore Business Park,

Inward Way,

Ellesmere Port,

Cheshire

CH65 3EN

Approved Body Number 0120

EU Declaration Of Conformity available at

<https://www.globestock.co.uk/technical/declarations-of-conformity/>

UK Declaration Of Conformity available at

<https://www.globestock.co.uk/technical/declarations-of-conformity/>

1. Important Notice

READ THE EQUIPMENT LABELS AND 'USER INSTRUCTIONS' BEFORE USING THIS PRODUCT.

BEFORE USING THIS EQUIPMENT IT IS ESSENTIAL THAT USERS ARE FULLY AWARE OF HOW THE EQUIPMENT OPERATES, WHERE IT SHOULD BE USED, WITH A PREDETERMINED ACTION PLAN FOR BOTH THE USE AND RECOVERY SHOULD AN EMERGENCY ARISE. WHEN USED IN COMBINATION WITH ANY OTHER EQUIPMENT DESIGNED TO BE USED WITH THIS TRIPOD PLEASE BE AWARE OF ANY POTENTIAL DANGERS THAT MAY ARISE FROM THAT COMBINATION AND ACCOUNT FOR IT DURING THE RISK ASSESSMENT.

This product has been developed to enable the safe entry/exit of personnel into a confined space or to an area of restricted access. It is recommended for use in conjunction with the G.Winch and/or the G.Saver II and/or G.Stop fall arrest and retrieval devices. Third party devices are not recommended.

This product can protect against potential falls occurring during use and provide a retrieval system for use in an emergency or an unforeseen occurrence.

This equipment is for use where other means of carrying out the work or routes of access are not practical.

Please observe the Maximum Working Load of the G.Tripod (200kg for personnel), and of all associated equipment. During use there must always be a second person present to supervise/operate the G.Tripod and associated equipment. Both the person entering the confined space and the equipment operator should be adequately trained.

This equipment is for single person use, with an energy absorber to EN355.

This equipment shall not be used outside of its limitations, or for any purpose other than that for which it is intended.

It is prohibited to make any alterations or additions to this equipment without the prior, written consent of Globestock Ltd. Any necessary repair will be carried out by Globestock Ltd, or by an authorised Globestock Ltd service agent, in line with our procedures.

The safe useable life of the product is determined by regular assessments carried out by Globestock or an approved Globestock agent. During such assessments and subsequent load testing a judgement will be made on it's suitability for future use.

If this product is resold outside of the original country that it was purchased, it is the responsibility of the seller to provide instructions for use, maintenance, periodic examination and repair in the language of the country where it is to be used.

Under PD CEN/TS 16415:2013 this equipment is suitable for two person use.
There is a maximum working load of 250kg for equipment.

PRIOR TO USE:

A formal 'Risk Assessment' should be carried out, considering use and the emergency rescue procedure. An emergency contingency plan must be in place to rescue the worker in the event of an emergency, before entering the confined space or area of restricted access to carry out work.

Users should be fully conversant with the operation of the equipment.

The 'Before Use Checks' should be performed (see section 4 – Inspection Before Use).

For all equipment being used, verify that the maximum working load is not exceeded.

2. G.Tripod

The G.Tripod is a lightweight, transportable, aluminium tripod typically used during confined space access or down hole applications. It is suitable for use as a fall arrest anchorage device.

It is available in two sizes, Compact (GSE230C) and Standard (GSE230S).

For Example: Used mounted over entrance hole, for personnel entering areas of restricted access or for confined space entry.

The tripod has three overhead pulleys to guide and position safety lines or fall arrest/load arrest/retrieval devices. Under the tripod head there are two attachment eyes for connecting a range of accessories and fall arrest equipment.

The G.Tripod is transported in its folded configuration. The legs fold out and are locked into position with a retained lock pin. The tripod legs can be easily extended to accommodate a range of different working heights.

The G.Tripod is quick and easy to set-up ready for work. A range of fall protection and associated equipment can be attached to the tripod legs ready for use.

G.Tripod fitted with G.Saver II mounting bracket (available separately).



3. Considerations For Use.

- Generally, the tripod feet should not be less than 30cm from the edge of the hole or opening used for access. For cases where the feet are nearer than this, steps should be taken to tether or restrain the feet from movement.
- It is advised to use the G.Tripod on stable, level ground. There are adjustments on the G.Tripods legs to allow for un-even ground or an incline, while keeping the Tripod head level. In instances such as these where there may be some doubt about stability, it is advisable to tether or securely restrain the feet of the tripod from movement. Do not stretch or pull the tripod legs from their natural positions.
- Do not Exceed the Maximum Working Load stated on the identification label of the G.Tripod. The label is located on the G.Tripod leg.
- Should any doubt arise about the safe condition of this device, or it has been used to arrest a fall, **DO NOT USE.**
- Return to Globestock or a Globestock authorised servicing agency for assessment, service and re-certification, before further use
- This equipment is intended for single person use under EN795:2012. During confined space entry there must be an additional person present at all times to operate the equipment.
- The Equipment operator should maintain communication at all times with the person(s) entering/exiting the confined space.
- The G.Tripod and associated equipment may only be used by trained or otherwise competent persons.
- Personnel Protective Equipment should be worn when using this equipment. For example gloves, safety glasses, safety shoes, head protection etc.
- Wear gloves to protect your hands when inspecting or handling the wire rope.
- Ensure the person's path of entry is free of obstructions.
- Attach the rope's safety hook of the fall arrest/retrieval device, directly to the person's body harness attachment point or the connection point on the carrier.
- Do not allow slack cable during use. This cable may tangle, foul, or hinder the safe retrieval of the user. It can cause 'serious harm' to the user in the event of a fall.
- Do not allow the rope safety line to pass over sharp edges, electrical items/cables.
- A clearly understood, predetermined action plan should be in place and implemented in the event of an emergency and before work can commence.
- Be aware of any medical condition that may affect the safety of the equipment user in normal and emergency use. If there is any doubt seek medical advice or do not use the equipment.

- It is essential for the safety of the user that the equipment is set up for use away from any potential hazard – such as a fall from height – and is used in such a way so as to minimise any potential for falls. When working below the G.Tripod precautions to minimise risk of injury or fall must be taken.
- When the G.Tripod is used as part of a fall arrest system, the user must be equipped with a means of limiting the maximum dynamic peak force exerted on the user during an arrest of 6kN.
- Under PD CEN/TS 16415:2013 this equipment certified for two person use.

4. Inspection Before Use

Before using the G.Tripod, inspect as follows. This should be performed in a safe environment ideally away from the confined space access hole. Ensure that the equipment's service period has not expired.

Inspection

- Check that all threaded fasteners on the tripod are present and secure.
- Visually check that the tripod is structurally sound, with no significant damage to the legs and feet, tripod head, pulleys and eye attachment points.
- Inspect the entire system for any signs of damage, wear or malfunction.
- Ensure that the locking pins function correctly and lock the legs into position.
- Check for the presence and legibility of the product label.

5. Setup For Use

If in any doubt please contact either a specialist or Globestock Ltd for advice.

Where possible, the equipment should be setup in a safe area and then be moved into place by two or more people, so that it is ready for use. Perform a final visual inspection, and the equipment is ready to use. The final setup configuration should be such that the potential for falls are minimised and the height of any fall is as low as possible.

a. Attaching To The G.Tripod

- The G.Tripod should be set up with the legs unfolded. Lock the tripod into its open position by locating the retained lock pin into the open hinge. With the legs locked into place, set the tripod down onto its feet.
- For assembly with rope based equipment, extract 3 metres of rope.
- The rope can then be fitted onto the tripod.
- Fall Arresters with a spring tensioned safety line, such as the G.Saver II, are best fitted to the tripods fixed leg. Pass the rope through the space between the heads of the tripod and ensure that the rope sits inside the rope retention pin on the tripod head.
- The G.Winch can fit to either side leg. With 3 metres of rope extracted, pass the rope through the space between the heads of the tripod and the rope is inside the rope retention pin. Ensure the screw gate of the carabiner is securely locked.

- Raise the G.Tripod to the required height. Take the first leg and extend it to the desired height setting. Repeat with the remaining legs. Fix the legs at the required lengths with the retained leg adjustment clip, passing the pin through the holes in the outer and inner leg tubes.
- Attach the G.Saver II to one of the upper legs of the G.Tripod via the appropriate block bracket, as shown in figure 1 on the next page.
- With the G.Winch on the ground, unscrew the mounting bracket lever arms, so that the winch is ready to fit to the G.Tripod.
- Fitting the G.Winch to the G.Tripod is best performed by two people. Lift together, the G.Winch onto the upper leg of the tripod.
- One person holds the winch in place, with the weight of the winch supported by the tripod leg. The other person fastens the brackets to hold the winch onto the leg.
- Both the ropes hanging at the centre of the tripod can be attached back to their respective devices, taking up slack wire rope.
- The Access System can then be visually inspected before moving into place over the access hole.
- Ensure all locking Levers are tight and secure.
- Check that the attachment to the G.Tripod of the G.Winch and/or the G.Saver II is compliant with the G.Winch and the G.Saver II manuals.
- When attached to the G.Tripod via a suitable fall arrest device such as the G.Saver II, a full body harness is the only acceptable body holding device that can be used as part of this fall arrest system.

Figure 1



6. Inspection & Maintenance

Like all safety critical devices, the G.Tripod requires regular inspection and maintenance to ensure that the unit functions safely and correctly.

Repairs or servicing should never be carried out on site or in the field, and should only be completed by the manufacturer or a service agent approved by the manufacturer. Do not tamper with or modify the unit. Any alterations or additions to the equipment can only be carried out with the prior written consent of Globestock Ltd.

a. Periodic Examination (This satisfies the requirements of LOLER).

The G.Tripod should be periodically inspected by a competent person at **least once in every 6 months**, dependent upon the frequency of use, and the operating environment. The 'Examination Record' found at the back of this booklet, outlines the main examination criteria.

On passing this detailed inspection the record can be completed, signed off and the unit returned for use.

Any observed faults must be rectified by the manufacturer or an approved agent of the manufacturer. If necessary, or **in any doubt**, return the G.Tripod for service, test and re-certification. (See below).

It is recommended that the Tripod is marked with the date of when the next inspection is due.

b. Service, Test & Re-Certification

The G.Tripod must be serviced and re-certified annually in the event of a fall arrest or if any doubt should arise concerning the units condition.

Only a Globestock Ltd approved servicing agency can be used for this.

On completion of a service and retest, a new Test Certificate will be issued which validates the unit for a further year of use.

c. Cleaning, Storage & Transportation

The G.Tripod may be cleaned using warm water with a mild detergent. It should then be allowed to dry.

The unit should be stored in a clean, dry, chemical free environment.

When transporting the G.Tripod it should be boxed or retained to prevent damage or deterioration.

Any accessories/equipment/brackets must be removed prior to transportation.

Once the product has reached it's end of life it can be broken down and component parts recycled.

7. G.Tripod Specifications

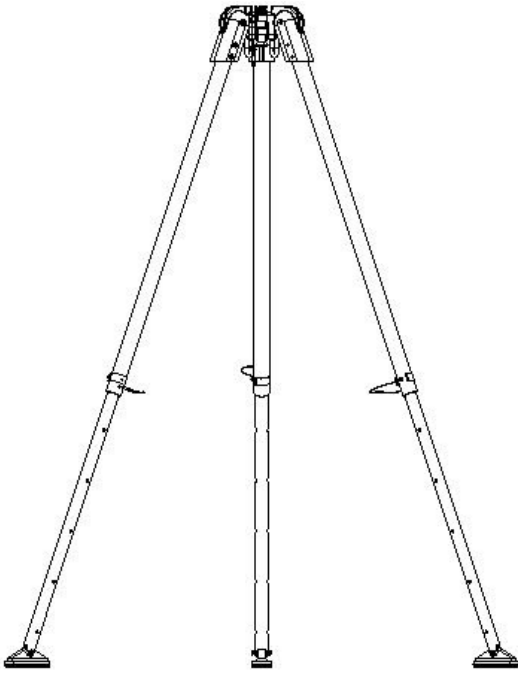

Maximum Height

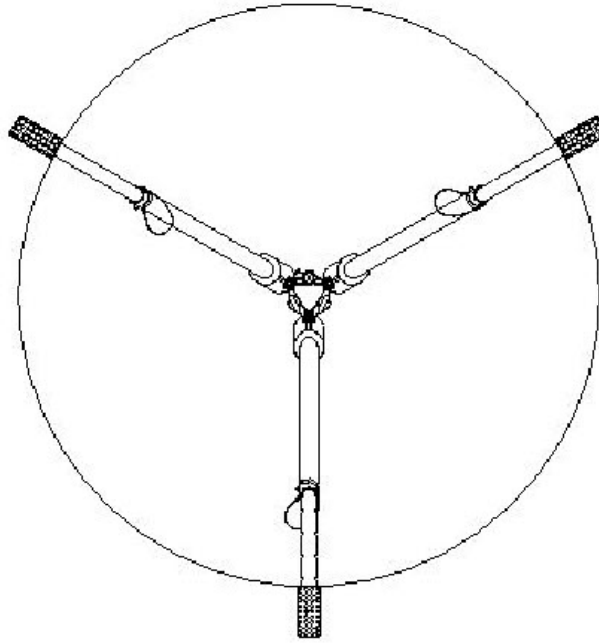

Leg Span

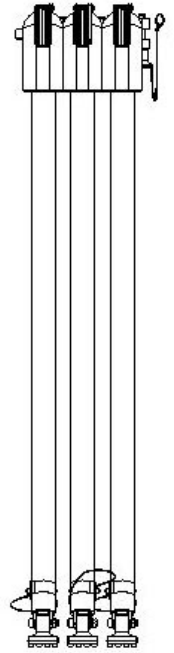

Folded

	GSE230S	GSE230C
Maximum Height	2.31m	1.75m
Anchor Point Height	2.14m	1.58m
Leg Span	1.75m	1.32m
Folded Height	1.53m	1.22m
Weight	20.8kg	18.0kg

① **GSE230S**
G.Tripod
Personal Fall
Protection & Lifting

GLOBESTOCK
SAFETY EQUIPMENT
www.globestock.co.uk

② Mile End Industrial Estate
Oswestry, Shropshire, SY10 8GA

③ **CE UK** ⑤ **CA** **i**

④ 0598 0120

For the use of 1 person only.
(BS EN 795:2012, EU 2016/425)

⑥ For the use of 2 people simultaneously.
(BSI PD CEN/TS 16415:2013)

⑦ **200kg MWL**
for Personnel
250kg MWL
for Loads

⑧ Date Of Manufacture:
January 2021
Serial number: ⑨

Product Label Definitions

1. Model Number
2. Manufacturers contact details
3. CE mark and Notified Body
4. UKCA mark and Approved Body
5. Read instructions prior to operation
6. Standards to which product conforms
7. Maximum Working Load
8. Date Of Manufacture
9. Serial Number

Globestock Ltd.
 Mile Oak Industrial Estate,
 Oswestry, Shropshire, SY10 8GA
 01691 654 966
 www.globestock.co.uk



EXAMINATION RECORD CARD

G.TRIPOD

GSE230S/C

Year Of Manufacture

Date of 1st Use

Serial No

Date Of Purchase

All fasteners present & secure

No severe corrosion/damage

Secure

No Significant Wear/Damage

Not Bent, Damaged or Cracked

Fixed Securely to Head Castings

Extend & Retract

Present & No Damage

Locate Securely

No Damage or Cracks

Legs Open Smoothly

Lock Legs Open

Retained on Captive Wire

No Damage or Cracks

Operate Satisfactorily

Present, Legible and Secure

Comments/additional Inspection Checks

Next Due Date

SIGN

DATE

Record Of Service
& Rectification